

Z70/...

Mat.: 1.2312 / 1080 N/mm²

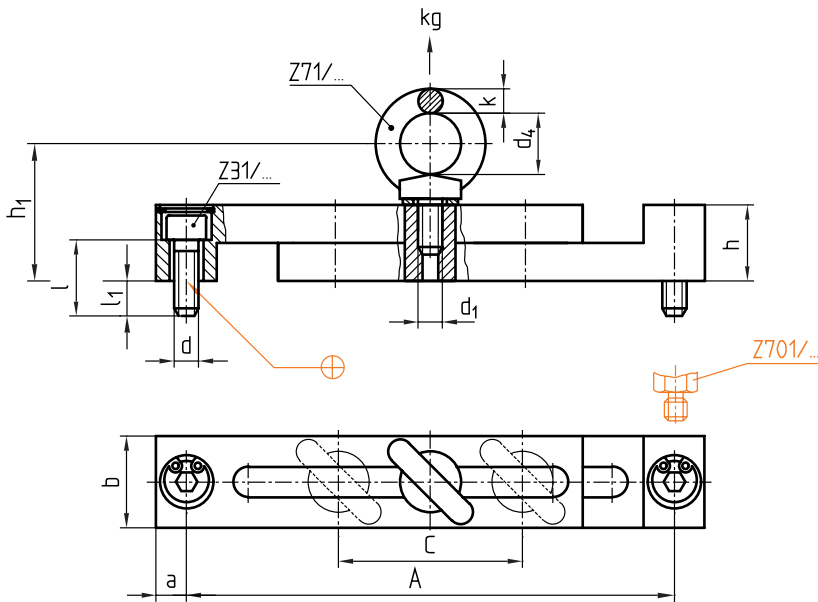

► Info

l ₁	Z31/dx _l	a	h	h ₁	d ₄	k	b	d ₁	C	A		kg	Typ	Nr./No.
										max.	min.			
11,5	Z31/ 8x25	10	25	43	20	8	30	M 8	40/ 80	180	140	140	1	Z70/1
14,5	Z31/10x30	12,5	30	52	25	10	40	M10	50/140	300	210	230	2	2
19	Z31/16x40	17,5	40	70	35	14	60	M16	60/195	430	295	700	3	3

Z701/...

Mat.: 1.0501 / 900 N/mm²

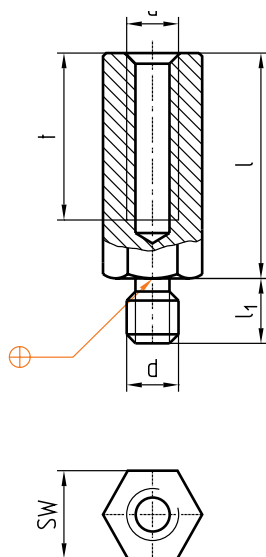

► Info

t	l ₁	d	SW	l	Nr./No.
27	15	M 8	19	50	Z701/ 8/19x50
		M10	22		10/22x50
		M16	27		16/27x50
32	20	M16	27		

This is trial version
www.adultpdf.com